

Operating Instructions

Type: MEK-18-S / MAK-18-S

Serial No. : _____

Article No.: _____



These operating instructions contain important information to be observed for hand extruder operation and maintenance. It is therefore imperative that they be read and their contents fully understood by the operators before the hand extruder is placed in service.



Hand Extruder MEK-18-S / MAK-18-S

Scope of delivery:

Please check that the delivery is complete.

The delivery comprises:

- 1 hand extruder
 - 1 handle
 - 1 welding shoe, machined 1)
 - 1 extruder stand
 - 1 hot air hood
- 1) Container engineering design: fillet weld a = 7mm, 40mm long
1) Landfill construction design: sheeting/film weld 25mm, 40mm long

Contents

1	GENERAL	4
2	SAFETY	4
2.1	IDENTIFICATION OF INFORMATION IN THE OPERATING INSTRUCTIONS	5
2.2	PERSONNEL QUALIFICATION AND TRAINING	5
2.3	RISKS RESULTING FROM NON-OBSERVANCE OF THE SAFETY INSTRUCTIONS	5
2.4	SAFE WORKING PRACTICES	5
2.5	SAFETY INSTRUCTIONS FOR OPERATOR / OPERATING PERSONNEL	5
2.6	SAFETY INSTRUCTIONS FOR MAINTENANCE, INSPECTION AND MOUNTING	7
2.7	UNAUTHORIZED MODIFICATIONS AND SPARE PARTS	7
3	TRANSPORT AND STORAGE	8
3.1	TRANSPORT	8
3.2	STORAGE	8
3.3	RETURN TO MUNSCH	8
4	PRODUCT DESCRIPTION	8
4.1	APPLICATION RANGE	8
4.2	GENERAL	8
5	STARTUP AND SHUTOFF	8
5.1	GENERAL	8
5.2	PREPARATION	8
5.3	STARTING THE HAND EXTRUDER	10
5.4	WELDING WITH THE HAND EXTRUDER	11
5.4.1	Introducing the welding rod	11
5.4.2	Replacement and aging of welding rod	11
5.4.3	Welding direction / rate	11
5.4.4	Interruption of work	11
5.4.5	Shutoff	12
5.4.6	Transport/storage	12
5.5	SET TEMPERATURES ON TEMPERATURE CONTROLLER	12
5.5.1	Set temperatures	12
6	MAINTENANCE/INSPECTION	14
6.1	MAINTENANCE/INSPECTION OF MEK/MAK HAND EXTRUDER	14
6.2	DISMANTLING	14
6.2.1	Overview of spare parts/attachments	14
7	MALFUNCTIONS, CAUSES AND REMEDIES	16
7.1	TROUBLE-SHOOTING	16
7.2	FAULT DIAGNOSIS	16
8	TECHNICAL DATA	18

Hand Extruder MEK-18-S / MAK-18-S

1 General



These operating instructions must always be available at the place of use of the hand extruder.

The objective of these operating instructions is to support operators in familiarizing themselves with the hand extruder and in using its functions for the intended service.

These operating instructions provide important information for the safe, workmanlike and economical operation of the hand extruder. Their observance helps avoid danger, minimize repair costs and downtimes, enhance reliability, and extend the service life of the hand extruder.

These operating instructions must be observed by all persons working with/on the hand extruder. Such work includes, for instance:

- operation,
- maintenance, inspection and repair
- transport.

The hand extruder may only be mounted, operated and maintained by trained personnel.

In addition to the operating instructions and the national and local accident prevention regulations applicable at the place of use, the acknowledged technical rules for safe and proper working practices must be observed.

These operating instructions provide basic information to be observed for operation and maintenance. For this reason, it is imperative that they be read by the specialist personnel/Operator prior to placing the hand extruder in service and that they always be available at the place of use.

Apart from the general safety instructions under section "Safety", also the special safety instructions given under the respective sub-sections must be adhered to.



Non-observance of the safety instructions may cause hazards to persons and the environment or damage to the hand extruder.

Moreover, failure to observe the safety instructions may lead to the forfeiture of any damages.

Non-observance of the safety instructions may in particular involve the following risks:

- failure of important hand extruder functions,
- hazards to persons due to electrical and mechanical impacts including risk of burns,
- hazards to the environment due to vapour-phase hazardous substances,
- risk of fire.

2 Safety

These operating instructions provide basic information to be observed for operation and maintenance. For this reason, it is imperative that they be read by the specialist personnel/Operator prior to placing the hand extruder in service and that they always be available at the place of use.

Safe operation of the hand extruder presupposes that the instructions under section 1 – General – of these operating instructions are complied with. In no case must the limit values indicated be violated.

Intact and unaltered hand extruders conform to the applicable codes and standards and meet all regulatory limit values regarding EMC (electromagnetic discharges and interference immunity). For the country-specific limit values to be observed, the Operator should consult the local electric utility. Nevertheless, the hand extruders emit electromagnetic fields within the acceptable limits. Electromagnetic fields may interfere with the operation of vital electronic devices (e.g. cardiac pacemakers). Persons wearing a cardiac pacemaker should therefore consult their physician before using the machine.

In addition to the operating instructions and the national and local accident prevention regulations applicable at the place of use, the acknowledged technical rules for safe and proper working practices must be observed.

Apart from the general safety instructions under section "Safety", also the special safety instructions given under the respective sub-sections must be adhered to.

Any working practices posing a safety risk are prohibited.

2.1 Identification of information in the operating instructions

In these operating instructions, safety instructions whose non-observance may cause hazards to persons are identified with



Hazard symbol according to DIN 4844 – W 9

for general hazards and with



Hazard symbol according to DIN 4844 – W 8

for electrical hazards.

Safety instructions whose non-observance may cause damage to the hand extruder and its functions are marked with

CAUTION

Instructions directly indicated on the hand extruder must be strictly followed and kept in a fully legible state.

2.2 Personnel qualification and training

The operating, maintenance and inspection personnel must possess appropriate qualification for the work to be performed. Functional and technical responsibilities and supervision of the operating personnel must be clearly regulated by the Operator. Where the personnel do not have the necessary skills and knowledge they must be trained and instructed (e.g. a DVS basic welder training in extrusion welding). A detailed instruction into hand extruder operation will be provided by the Manufacturer/Supplier on request. Furthermore, the Operator has to make sure that the contents of the operating instructions is fully understood by the operating personnel.

2.3 Risks resulting from non-observance of the safety instructions

Non-observance of the safety instructions may cause hazards to persons and the environment or damage to the hand extruder. Moreover, failure to observe the safety instructions may lead to the forfeiture of any damages.

Non-observance of the safety instructions may in **particular** involve the following risks:

- failure of important hand extruder functions,
- hazards to persons due to electrical and mechanical impacts including risk of burns,
- hazards to the environment due to vapour-phase hazardous substances,
- risk of fire.

2.4 Safe working practices

The safety instructions given in these operating instructions, the applicable national accident prevention regulations and any existing in-company work instructions, operating and safety procedures issued by the Operator must be followed.

2.5 Safety instructions for Operator / operating personnel

- Before placing the hand extruder in service, check the mains voltage and frequency against the data indicated on the type tag. The allowable tolerances are $\pm 5\%$ for voltage and/or $\pm 2\%$ for frequency.
- According to VDE 0100 §55, the hand extruder must be operated via a residual current-operated circuit breaker or an isolating transformer.
- **CAUTION** During hand extruder operation (under load), a voltage of not less than 230 V¹⁾ must be available at the connector of the hand extruder.
- When using an extension cable, make sure to observe the minimum conductor cross-section. Use extension cables with protective conductor only.

Length [m]	Minimum cross-section [mm ²]
up to 19	4.0 ¹⁾
20-50	6.0 ¹⁾

1) for 230 V AC

Hand Extruder MEK-18-S / MAK-18-S

- Extension cables must be certified for the specific service conditions (e.g. outdoor service) and identified accordingly.

Always handle the connecting cable with care.

- Do not kink the connecting cable.
- Do not place any objects on the cable.
- Do not jam or squeeze the connecting cable, nor pull it over sharp edges.
- Protect the connecting cable from moisture.

-  Do not touch the mains connector or connecting cable with wet hands. Hold the cable always at the connector when plugging or unplugging it.

- **CAUTION** Power generator sets used for power supply must be designed for the following rated output:

≥ 4 x rated output of hand extruder

-  Never allow the hand extruder to come into contact with water: Hazard to persons and equipment, short-circuit risk.

- **CAUTION** Never operate the hand extruder without air supply; risk of hand extruder damage.

When using an external air source, make sure that the air supply line is adequately dimensioned.

- **CAUTION** The supply air must be clean, dry and free from oil and water.

-  The hand extruder must not be used in explosion hazard areas or flammable atmospheres.

Make sure that the hand extruder is firmly positioned during the extrusion welding job.

The connecting cable, welding rod and hose for external air supply, if applicable, must be freely movable and must not obstruct the operator or third parties in their work.

-  Hold and touch the hand extruder only on the handles provided for this purpose.

- **Do not** touch bare metal parts (including hot air hood) either with or without gloves. These parts reach temperatures of up to 350 °C.
- Attachments may be damaged or impaired in their function if subjected to the full weight of the hand extruder.
- Bare metal parts must not come into contact with other items during the work or work breaks (e.g. cooling).

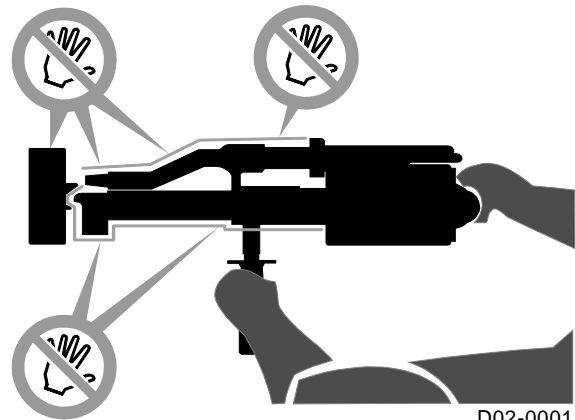

-  Contact of combustible components with hot bare metal parts poses a risk of fire!

Do not use synthetic gloves!

- Do not direct the hot air jet of the hand extruder towards living beings or temperature-sensitive items.

Safety distance: 2 m radius

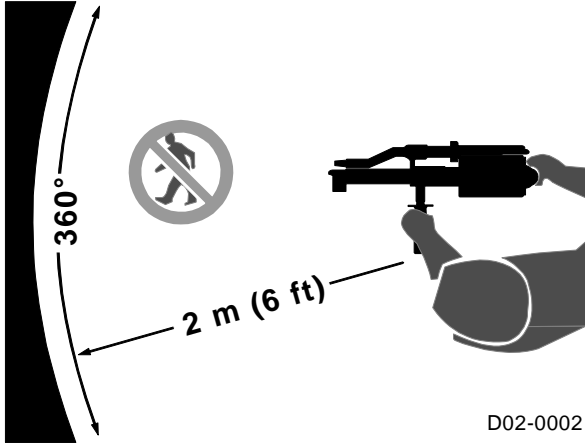

- Use suitable personal protection equipment for overhead work (e.g. hard hat, safety goggles, gloves, protective clothes ...) to guard against falling items.
- During work breaks and after completion of the welding job, place the hand extruder on the rests supplied for this purpose.



CAUTION The hot air hood must be remounted.



Make sure that the hand extruder is firmly positioned!

Deposit the hand extruder in a dry location.

After completion of the welding job, cool the hand extruder to safe-to-touch temperature, using the air supply system.

-  Do not operate, dismantle or carry out any modifications on the hand extruder, if
 - the connecting cable or the mains connector is defective,
 - safety devices are damaged,
 - foreign matter or liquid has penetrated into the hand extruder,
 - the unit does not work properly or there are unusual changes in its operating behaviour.
-  Never allow the hand extruder to come into contact with water: Hazard to persons and equipment, short-circuit risk.

2.6 Safety instructions for maintenance, inspection and mounting

The Operator is responsible for ensuring that maintenance, inspection and mounting activities are performed by authorized and **qualified personnel** who are thoroughly familiar with the operating instructions.

- As a rule, the hand extruder must be shut off and the connector unplugged before proceeding to any work on the unit. The shutoff procedure for the hand extruder described in the operating instructions must be strictly observed.
- Electrical hazards must be ruled out (for details, see VDE guidelines and the standards of your local electric utility, for instance).



-  VDE 0701 (IEC 335) prescribes the measurement of the protective conductor resistance, insulation resistance and leakage current after each repair or modification to electrical equipment. Furthermore, a visual inspection of the unit and its connecting cable as well as voltage and current measurements and a function test must be carried out.
- Ensure the safe and environmentally compatible disposal of media, auxiliary materials and replaced parts!
- Remount and reactivate all safety and protective devices immediately on completion of the maintenance, inspection or repair work.

2.7 Unauthorized modifications and spare parts

Modifications or changes to the unit are only allowed after consultation with the Manufacturer. In the interest of safety, only original spare parts and accessories authorized by the Manufacturer should be used. The use of components other than the original spare parts may invalidate the Manufacturer's liability for any resulting damage.

Hand Extruder MEK-18-S / MAK-18-S

3 Transport and Storage

3.1 Transport

- ⚠ Before transport and storage, make sure that the hand extruder has cooled down to safe-to-touch temperature.

- ⚠ Hold and touch the hand extruder only on the handles provided for this purpose.

Do not touch bare metal parts (including the hot air hood) – whether with or without gloves - before having made sure that they are safe to touch. These parts reach temperatures of up to 350 °C during operation.

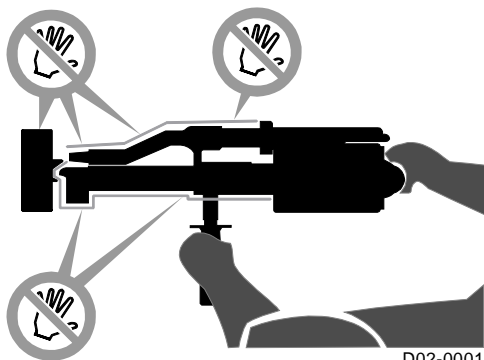

- Always transport or store the hand extruder in such a way as to preclude any mechanical loads on the attachments.

If parts have been removed for transport purposes, mount and fasten them carefully before restarting the hand extruder!

Transport of the hand extruder in MUNSCH's original shipping case is recommended.

3.2 Storage

- Store the hand extruder in a dry and frost-free place.
- Protect the hand extruder from unauthorized access.
- Special preservation is not required.

3.3 Return to Munsch

Should it become necessary to return the hand extruder to MUNSCH Kunststoff-Schweißtechnik GmbH, always use the original shipping case.

4 Product Description

4.1 Application range

The application range of the hand extruder is defined by the data on the type tag and the service limits indicated in these operating instructions.

CAUTION Operation of the hand extruder outside the service limits stated in these operating instructions is subject to the Manufacturer's prior approval.

4.2 General

Type **MEK** is a hand extruder with external air supply.

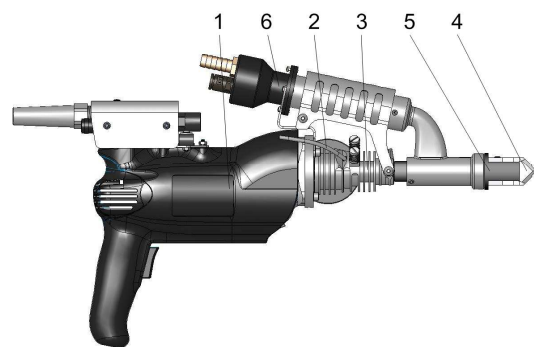

Type **MAK** is a hand extruder with integrated air supply (Autoair).

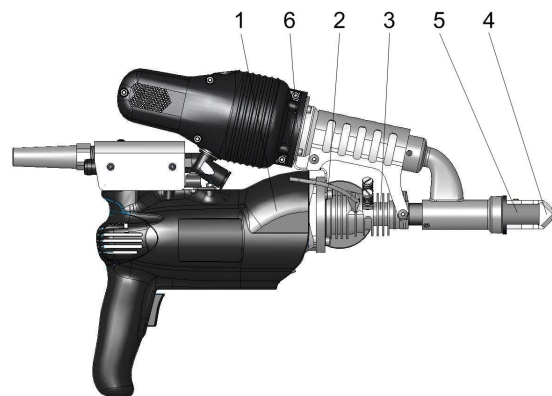

For both types of hand extruder, the following parameters can be freely selected:

- welding rate,
- hot air temperature,
- melt temperature and throughput; the melt throughput can be controlled downward from the maximum value, **firstly** by using 3 mm instead of 4 mm welding rod and, **secondly** by reducing the speed using the button on the controller.

CAUTION Too low a speed will cause drive overheating!

Driven by a powerful electric motor (1), the welding rod (2) is fed into the extruder (3) and granulated by the extruder screw in the process. The screw forces the granulate into the extruder nozzle, melting it into a homogeneous, completely plastified mass. As the molten material exits the extruder nozzle, it is moulded by a welding shoe (4) to the geometry of the weld seam to be deposited.

Preheating of the base material to be joined is accomplished by a preheating nozzle (5) which is supplied from an integrated hot air unit (6). Air is supplied either from an external compressor or an on-board blower.

As the MAK-18-S / MEK-18-S does not provide for separate setting and control of the hot air temperature and the melt temperature, we would like to point out that these two extruder types do not meet all of the DVS requirements and may therefore not be used for certain types of welding job.

The melt temperature must have reached the preset **start interlock temperature** for the startup timer to be activated. After the startup timer has timed out, the start interlock will be released and the extruder can be started.

The temperature-controlled start interlock prevents the drive from starting if there is still unmolten material in the extruder, thus precluding damage to the unit.

The output rate is variable so that the preheat temperature can be matched to the weld thickness

5 Startup and Shutoff

5.1 General

In addition to the operating instructions and the national and local accident prevention regulations applicable at the place of use, the acknowledged technical rules for safe and proper working practices must be observed.

Any working practices posing a safety risk are prohibited.

Before starting / shutting off the hand extruder, make sure to carefully read the instructions under section "Safety".

Only trained and qualified personnel may be assigned to the operation of the hand extruder.

5.2 Preparation

- Place hand extruder on a firm support and secure them against toppling over as shown in the illustration.

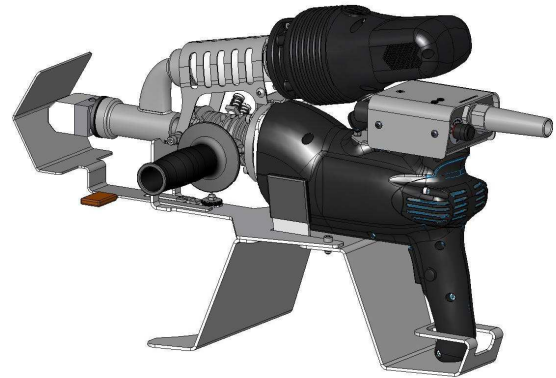

- Mount hot air hood

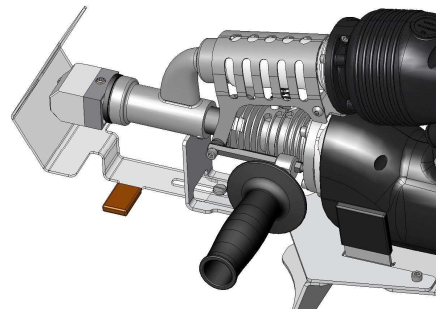

- Position handle
Loosen handle (55) and move it to the ideal working position by pushing it back and forth. The handles of these hand extruder models can also be swivelled upward and downward.

- **Only for type MEK hand extruder with external air supply:**

Connect the hand extruder to the external air source using the hose coupling LW 13 / NM 7.2 provided for this purpose (quick connect-disconnect); set air rate to 300 l/min at 0.4 bar. A suitable controller with flow metering function is recommended for setting the air rate.

CAUTION The supply air must be clean, dry and free from oil and water.

Never connect an external air source to a MAK hand extruder.

Hand Extruder MEK-18-S / MAK-18-S

- Mount welding shoe
 - Select the welding shoe required for the specific weld geometry or machine a welding shoe blank to the required geometry.
 - Observe DVS 2207 Guideline, Part 4 for machining welding shoe blanks.
 - Mount welding shoe to the hand extruder in the position required for welding.

Observe welding direction!
Tighten set screw (25).

- **CAUTION** The hot air hood must be in place.

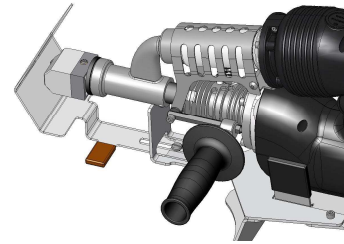

- The welding shoe including preheat nozzle can be rotated through 360° by releasing the set screw (25). After rotating the welding shoe, tighten set screw (25) to fix the welding shoe in place for the welding operation.

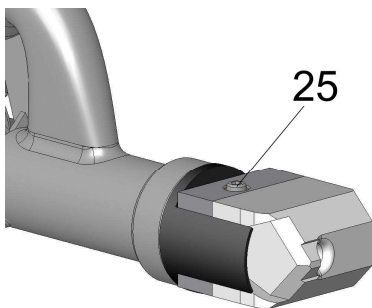

- **CAUTION** Start external air supply for MEK hand extruder.
- **CAUTION** Plug in mains connector.
- **CAUTION** In the case of the MAK hand extruder with integrated air supply, the blower must start automatically.
- **CAUTION** Once air exits the preheat nozzle (4), set the desired temperature on rotary button (1).

Care must be taken to ensure that the preheat nozzle provides intensive and uniform preheating (melting) of the base material over the entire joint width at as low a hot air temperature as possible. For larger weld seam widths, a wider preheat nozzle is available as an accessory.

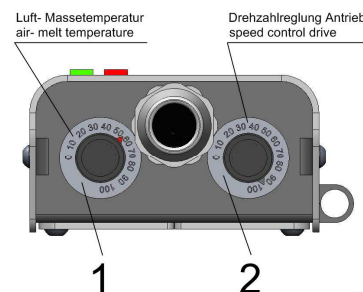

5.3 Starting the hand extruder



Observe section "Safety".

- **CAUTION** Never operate the hand extruder without air supply. Otherwise the unit may suffer severe damage.
- **CAUTION** Before plugging in the mains connector, check that the drive unit is not set to continuous operation.
- For the operation of the temperature controller, see section 5.5 "Set temperatures". For temperature settings, see page 12.
- **The hand extruder will reach its operating temperature after about 10 to 15 minutes.**